

Fig. 1.

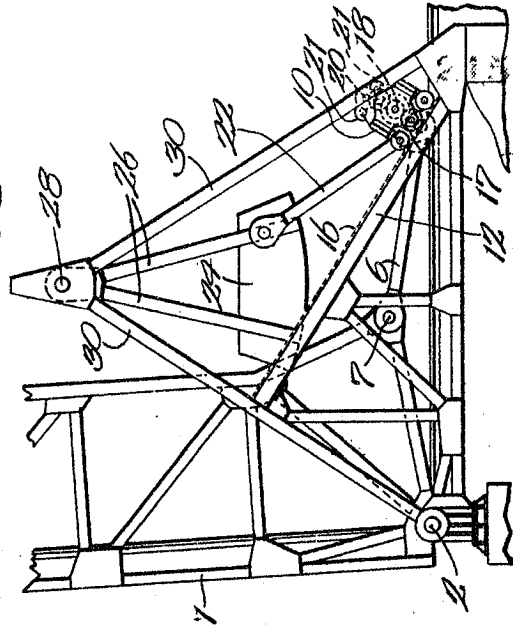

Fig. 3.

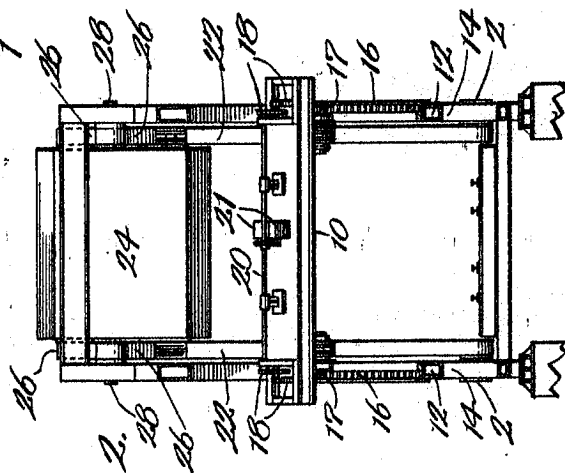

Fig. 2.

Certified to be the drawing referred
to in the specification hereunto annexed.
June 25, 1921

Witnesses:

Charles M. Price
Esther J. Levy.

June 25, 1921.
Chicago, Illinois.

Hugo A. F. Abt, Inventor
by Cheever & Cox attorneys

5

My invention relates to bascule bridges, and the objects of the invention are: first, to provide a structure in which the counterweight is mounted upon a separate support; second, to provide a structure in which the counterweight is mounted high enough to clear both during erection and other times the vehicles traveling on the roadway; third, to provide a structure in which the counterweight rotates oppositely to the bridge leaf; fourth, to provide simple and efficient means for actuating the moving parts.

I accomplish my objects by the mechanism illustrated in the accompanying drawings in which

Figure 1 is a side elevation of a bridge embodying my invention, the bridge leaf being shown lowered in operating position;

Figure 2 is a sectional elevation on the line 202, Figure 1;

Figure 3 is a side elevation similar to Figure 1, but showing the counterweight lowered and the bridge leaf raised.

Like numerals denote like parts throughout the several views.

My invention is concerned primarily with bascule bridges of the trunnion type, and in the form illustrated, the bridge leaf 1 is rotatably supported on trunnions 2 carried by the abutment or foundation 3. At the outer end the bridge leaf when lowered is supported upon the foundation or abutment 4.

Attached to the inner end of the bridge leaf, near the top of the frame, are links 6 pivotally connected to the frame by the pins 7. The inner ends of the links are pivotally con-

6

nected to motor carriages 10 adapted to travel on inclined tracks 12. These tracks are mounted on a stationary frame work 14. The tracks have toothed racks 16 parallel and adjacent to them which engage a pair of pinions 17 forming part of gear trains 18 driven by a common pinion shaft 20 which derives its power from a pair of motors 21. It will be evident that when the motors rotate in one direction or the other they will cause the motor carriage to travel up or down the tracks 12, according to the direction of rotation and, as the carriage is connected to the bridge panels by the links 6, its movement will cause the bridge leaf to rise or descend.

The motor carriage is connected by one or more links 22 to a counterweight 24 carried in a frame 26 adapted to swing about stationary pins 28. These pins are mounted on the top of a stationary frame 30. The parts are so constructed that the counterweight rotates in a counter direction to the bridge leaf and is suspended high enough to clear at all times, whether raised or lowered, the vehicles passing along the roadway beneath.

In operation the movements of the motor carriage up and down along the tracks 12 cause the bridge leaf to raise and lower and the counterweight to lower and raise respectively. Instead of having a common pivot the bridge leaf and counterweight have separate pivots located at a considerable difference of elevation; and instead of rotating in the same direction about their pivots, rotate in opposite directions. By preference the counterweight pivot is also considerably further back on the abutment. There are several advantages in this. In the first place, the entire weight of the moving parts of the structure is not carried by a single pair of trunnions but is distributed, the

2 65906

weight of the bridge leaf being carried by one pair of trunnions and the weight of the counterweight being carried by an entirely different set located above, and both horizontally and vertically remote from the first set. This distribution of the weight makes it possible to employ structural members of lighter dimension and also lighter abutments. Another advantage is that the counterweight and its supporting structure may be erected without interference with traffic. It is common practice to employ as counterweights metallic receptacles filled with concrete. I prefer to follow this practice, and with my construction the receptacle may hang down pendant. prior to the connection of the operating links 22, and the concrete may be poured while the receptacles hang in this natural position. The fact that the receptacles are down, however, does not mean that traffic is interfered with, because the bottom of the receptacles are, in the preferred form, higher than the clearance line of traffic which, according to standard practice, is usually 22 feet above the level of the rails or roadway. This feature greatly simplifies the erecting and pouring of the counterweights. Another advantage is that it becomes unnecessary to provide a pit or other space beneath the level of the bridge floor into which the counterweight may descend when the bridge leaf is raised. No part of the bridge structure itself (excluding the foundations) descends at any time beneath the level of the bottom of the bridge leaf. Still another advantage is that the aggregate length of the structure may be held to a minimum, the counterweight in swinging away from pendant position swinging inward towards the bridge leaf.

It will be noted that there is equal angular motion of

Cheever & Cox
Patent Lawyers
Chicago

the bridge leaf and of the counterweight, thus producing accurate counterbalancing at all times and in all positions.

It will be evident by reference to Figure 1 that the line of the rack 16 bisects the angle between the bridge leaf link 6 and the counterweight link 22. In other words, if the line of travel of the power device were produced or extended upward, the angle which it makes with the bridge leaf link 6 would be the same as the angle which it makes with the counterweight link 22.

Cheever & Cox
Patent Lawyers
Chicago

Having thus described my invention what I claim as new and desire to secure by Letters Patent is:

1. A bascule bridge having a rotatable bridge leaf, a rotatable counterweight, said leaf and counterweight having axes remote from each other, a power device, a link for connecting said leaf to said power device, and a second and separate link for connecting the counterweight to the power device.

2. A bascule bridge having a rotatable bridge leaf, a rotatable counterweight, a motor carriage, means for guiding said carriage, and independent connections between said carriage and said counterweight whereby said leaf and counterweight will be rotated simultaneously in opposite directions, angularly.

3. A bascule bridge having a rotatable bridge leaf, a rotatable counterweight, the axes of said leaf and counterweight being distant from each other, a motor carriage, an inclined track for said carriage, a power device for causing said carriage to travel upon said track, and connections between said carriage and said leaf and counterweight for actuating the latter.

4. A bascule bridge having a rotatable bridge leaf, a rotatable counterweight, the axes of said leaf and counterweight being distant from each other, a motor carriage, an inclined track for said carriage, a power device for causing said carriage to travel upon said track, and links leading from said carriage to said leaf and counterweight respectively and adapted to actuate them simultaneously in opposite angular directions.

5. A bascule bridge having a bridge leaf and a counterweight rotatable about parallel axes located at a distance

Cheever & Cox
Patent Lawyers
Chicago

X

4

from each other, a power device, a connection from the power device to the bridge leaf, and a separate connection from the power device to the counterweight for causing them to rotate equal amounts.

6. In a bascule bridge, the combination of a pivotally supported bridge leaf, a counterweight, a frame on which the counterweight is pivotally supported at a point remote from the bridge leaf pivot, a power device, a strut connecting the power device to the counterweight, and connections between the bridge leaf and said strut.

7. A bascule bridge having a pivotally supported bridge leaf, a counterweight, a frame on which the counterweight is pivotally supported at a point remote from the bridge leaf, a traveling power device, a strut link, connecting the power device to the counterweight, and a tension link connecting the power device to the bridge leaf.

8. A bascule bridge having a pivotally supported bridge leaf, a counterweight, a frame on which the counterweight is pivotally supported at a point remote from the bridge leaf, a traveling power device, a straight track on which said power device travels, and two connecting members, one for connecting the power device to the counterweight and the other connecting the power device to the bridge leaf, the produced line of travel of the power device bisecting the angle between said two connecting members.